

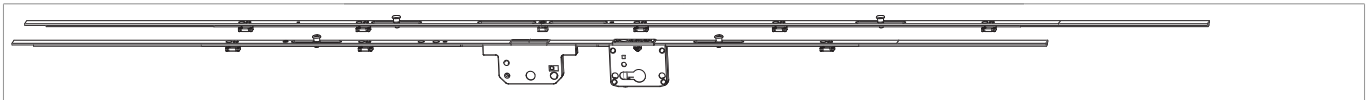







## 455594 - Getriebeset SKB-Z mit 2 i.S. Gr. 7 GM 950 FFH 2.101-2.300 DM 45 PZ Silber



### Technische Zeichnung



									
Silber	Gr. 7	DM 45	950	200	14	2	5	455594 <sup>1)</sup>	

<sup>1)</sup>Inhalt: 1x Getriebe, 1x Höhenteil

### Lehren

			
Lehre für Getriebe abschliessbar SKB für DM 17,5 - 50		1	465150
Einlegelehre für Getriebe und Höhenteil SKB-Z mit Halter 50 mm	1.701 - 2.400	1	211612
Lehrenkoffer für SKB		1	455659 <sup>1)</sup>

<sup>1)</sup>Lehre für Fräsung Scheren und Griff SKB-Z, Lehre für Getriebe abschliessbar SKB für DM 17,5 - 50, Klemmlehre zur Positionierung der Führungs- und Laufschiene SKB, Lehre zur Zentrierung der Schraublöcher für Lauschuh SKB, Anschlaglehre für Steuerteil SKB, Bohrerzentrierung, Gleiterentastung, Bohrer 3,2 mm, Bohrer 4 mm, Fräser 6 mm, Torxschlüssel T25, Torxschlüssel T40

Bohr- und Fräsbild

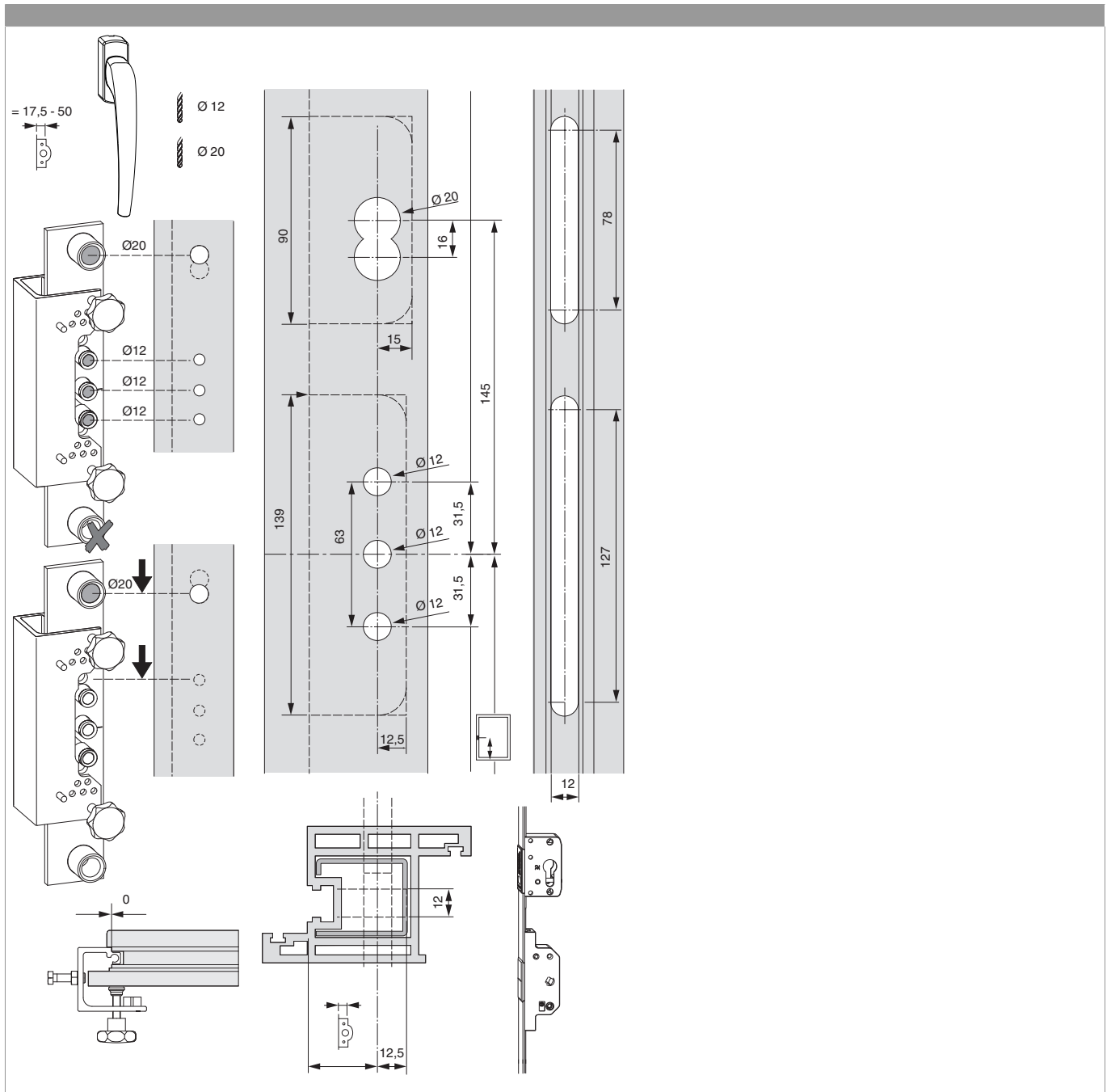

## Anpressdruckregulierung

i.S Zapfen und Verschlusszapfen

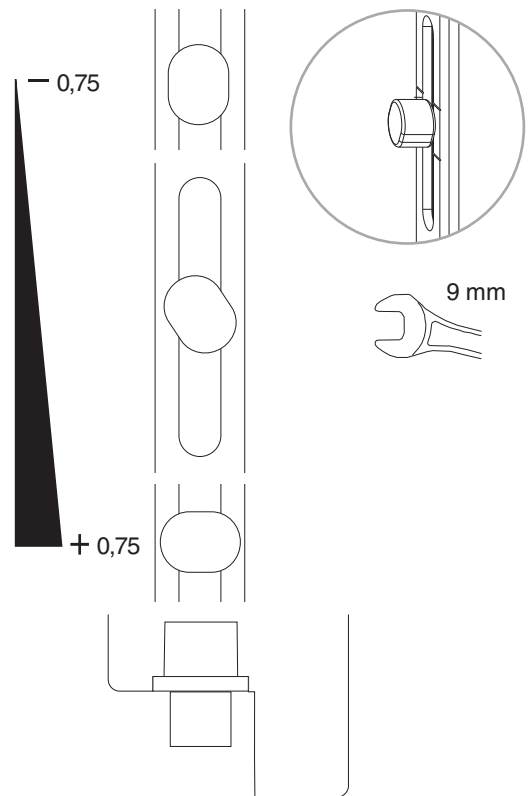
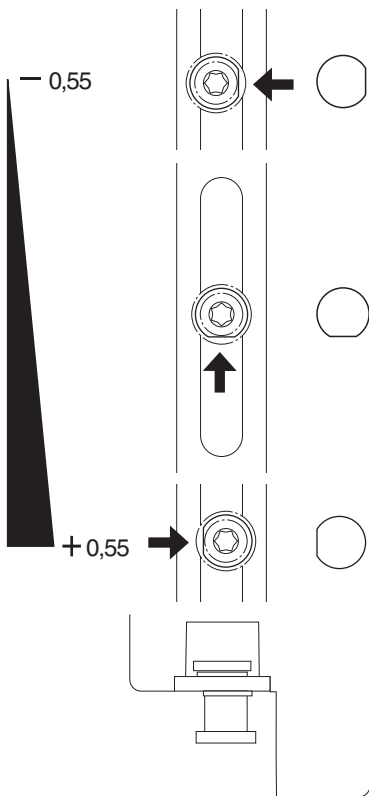
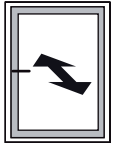

• nur für Größe 1050 und 1300