

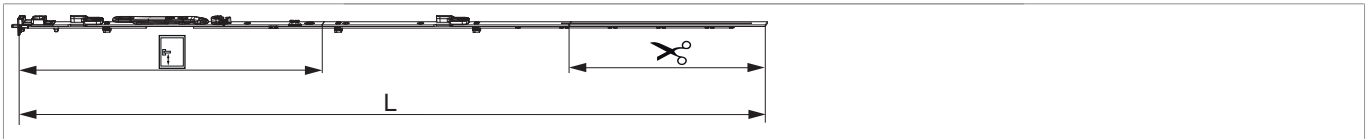







209507 - Stulpflügelgetriebe MM fix für Kippschwinge 840 für 1 VZ FFH 661-840 GM 300 Silber

Technische Zeichnung



				L				N^o
Silber	für 1 VZ	840	300	736,5	661 - 840	190	10	209507¹⁾

¹⁾Nur in Verbindung mit Dreh-Getriebe 840 mit Kippschwinge Art. Nr. 209590 verwendbar.

Schraubpositionstabelle

N^o		1	2	3	4	5	6	7	8	9	10	11	12	13	14	15
209507	5	37	91,5	251,5	383,5	429,5										

Stanzbild

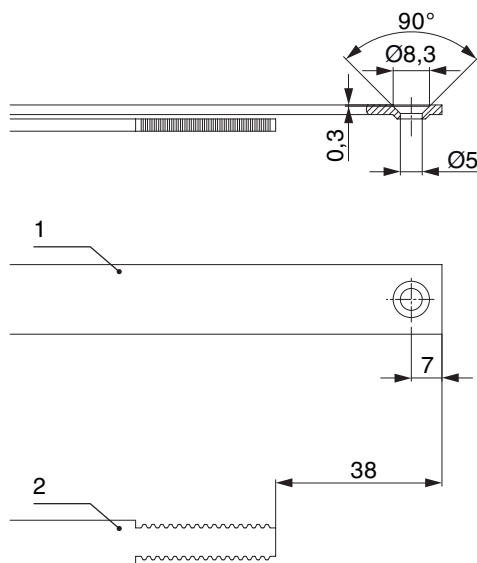

1. Stulp

2. Riegel

ACHTUNG: Mit offenen Spreizhebel ablängen!

Zahnkastenverbindung

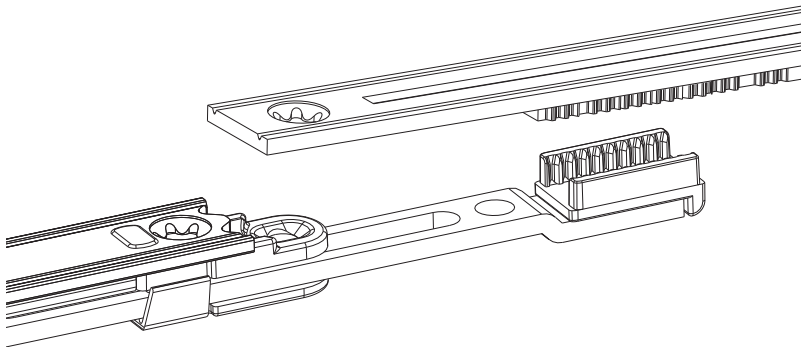

Stangenausschluss

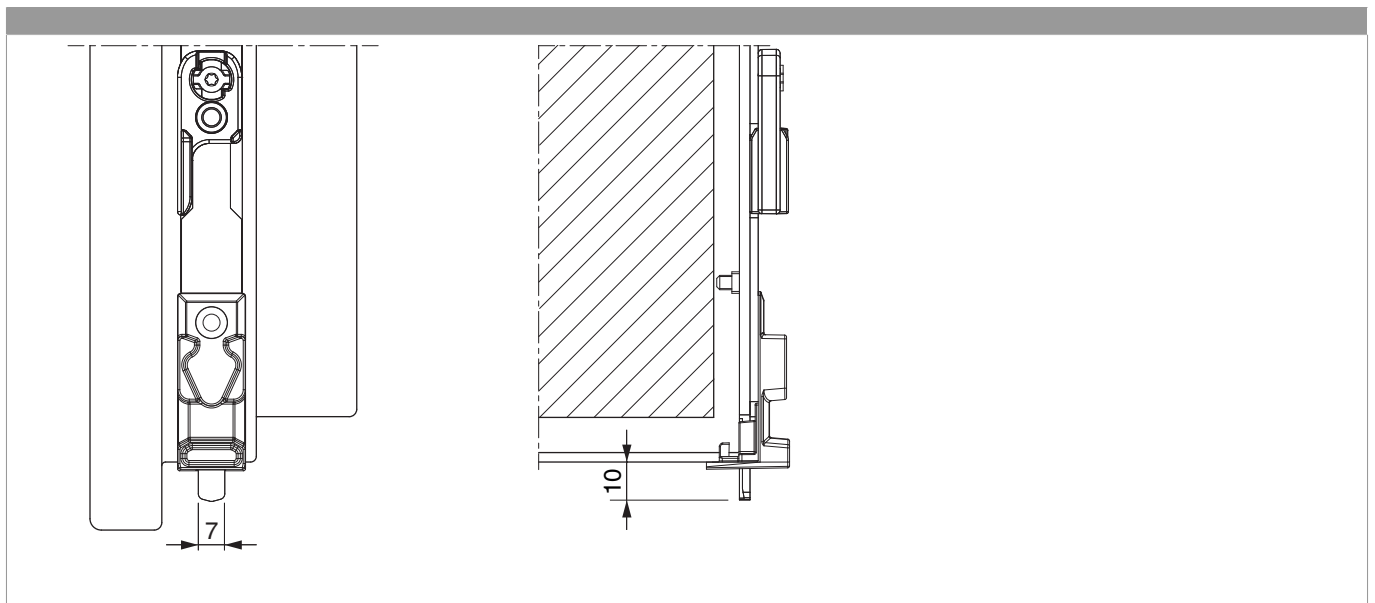

Montage

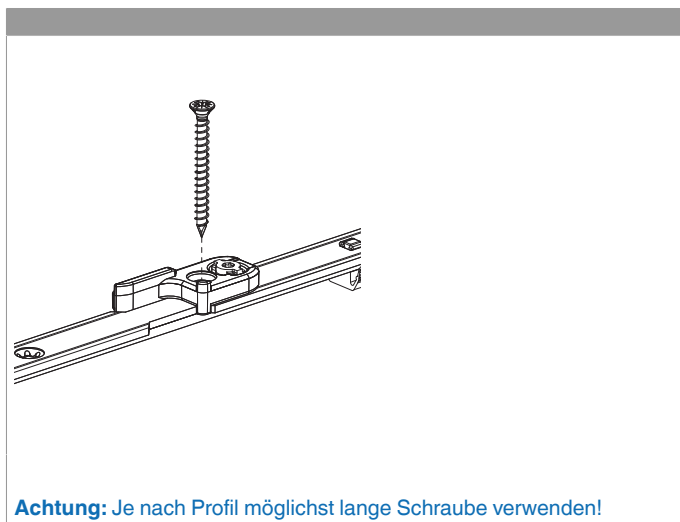

Einstellung des Wendeschließteils

Bajonettverschluß öffnen

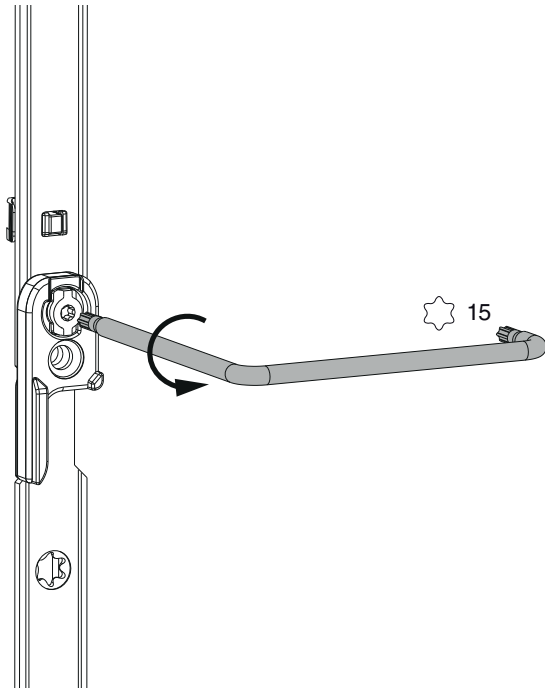

Schließteil wenden

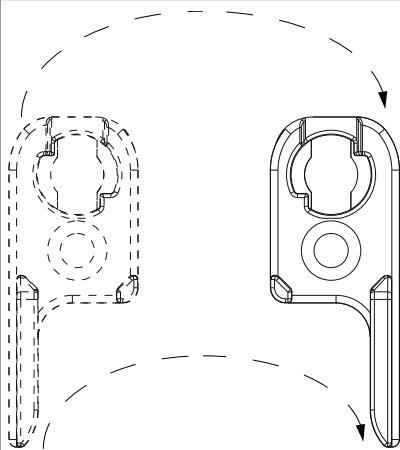

Bajonettverschluß schließen

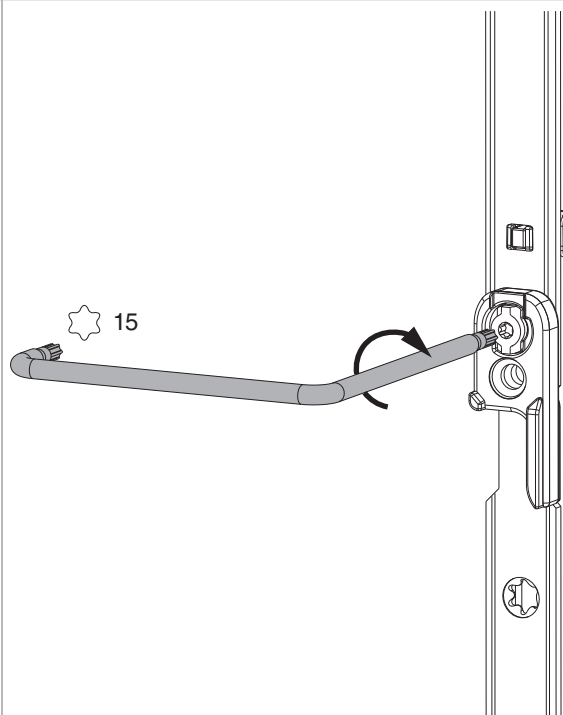



Gegenüberstellung der Kerbmarken

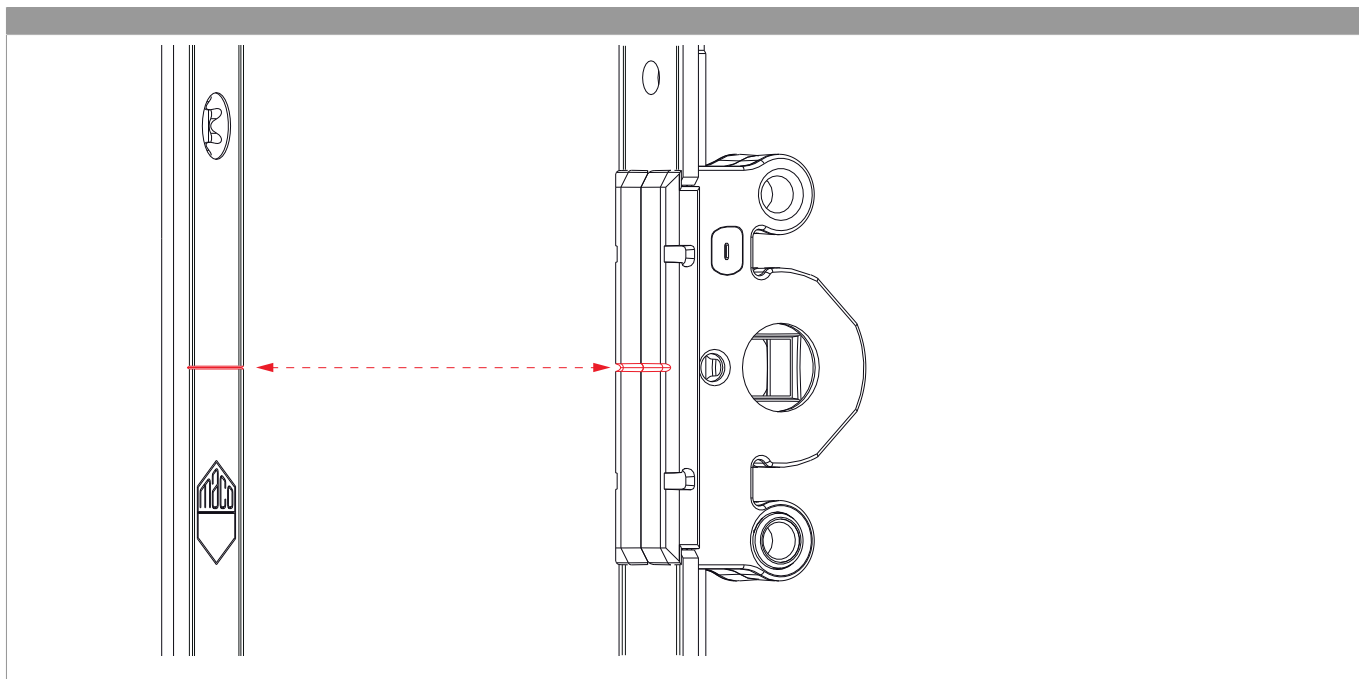

Einhängen und Aushängen des Stulpflügelgetriebes

